

## Radiator fan controlled timer

### Description

The bipolar integrated circuit, U 6044 B, is designed as a radiator fan controlled timer. After the ignition is switched off, the thermal switch of the engine can activate the

radiator fan via relay for a preset period, to support the cool-off process. In addition, an air-conditioning contact can switch on the radiator fan at any time.

### Features

- Delay time range: 4 s to 20 h
- Cool-off time starts when thermal switch is closed
- RC oscillator determines switching characteristics
- Relay driver with Z-diode
- Debounced input for coolant temperature switch
- Not debounced input for ignition key (Terminal 15)
- Low standby current
- Load dump protection
- RF interference protected
- Protection according to ISO/TR 7637-1 (VDE 0839)

### Cases:

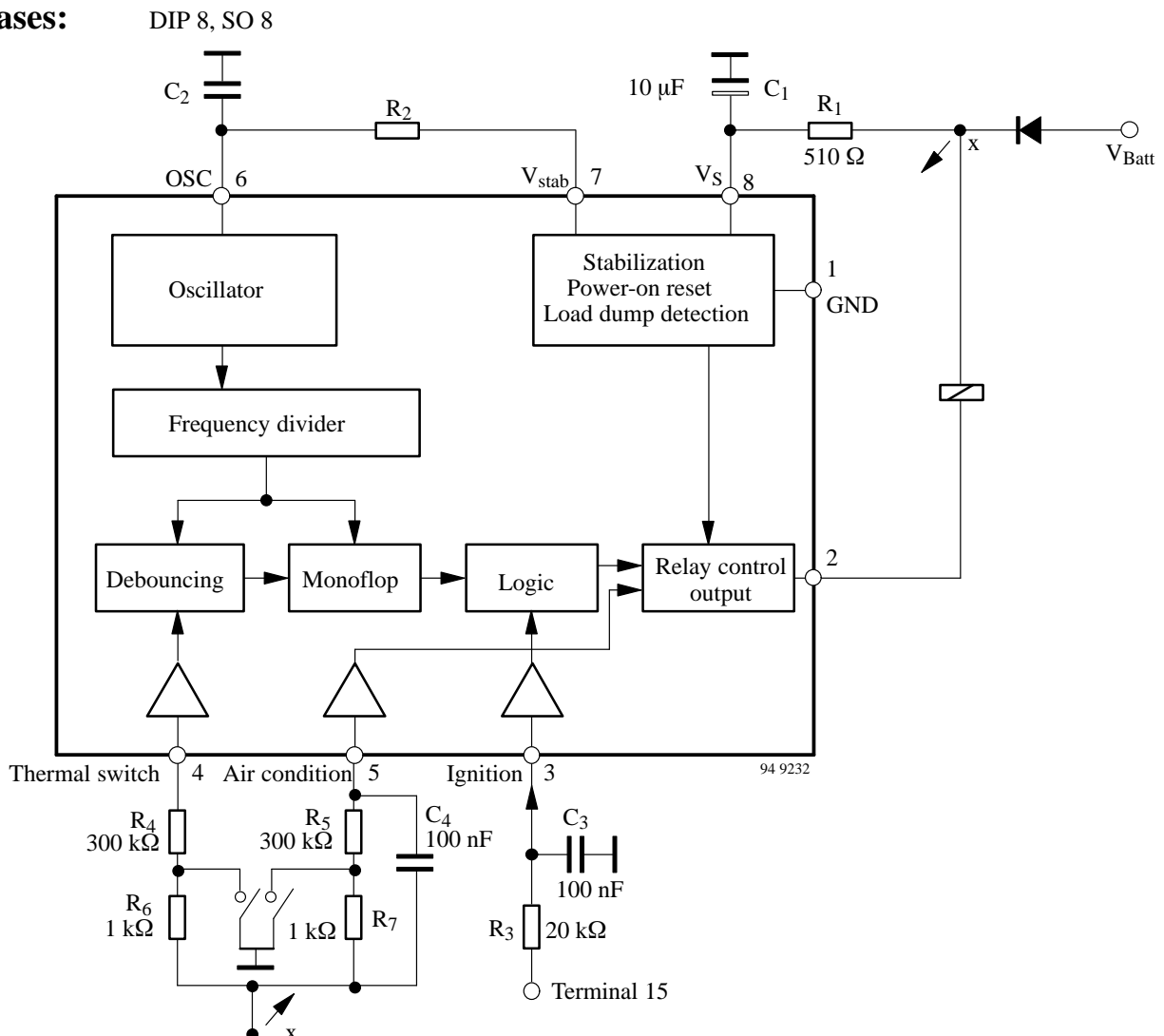
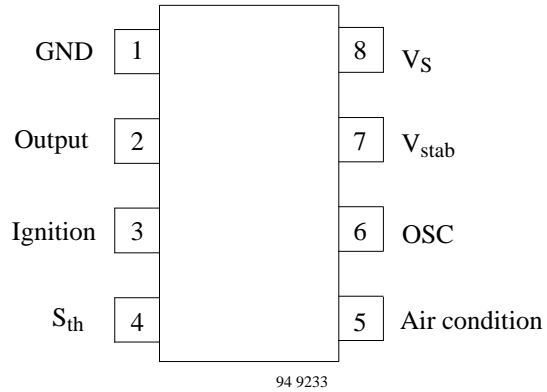

Figure 1 Block diagram with external circuit

## Pin Configuration

Pin	Symbol	Function
1	GND	Reference point, ground
2	Output	Relay control output
3	Ignition	Signal input, ignition
4	$S_{th}$	Thermal switch, input
5	AC	Air condition input
6	OSC	RC oscillator input
7	$V_{stab}$	Stabilized voltage
8	$V_S$	Supply voltage



## Functional description

### Power supply, Pin 8

For reasons of interference protection and surge immunity, the supply voltage (Pin 8) must be provided with an RC circuit as shown in figure 2a. Dropper resistor,  $R_1$ , limits the current in case of overvoltage, whereas  $C_1$  smoothes the supply voltage at Pin 8.

Recommended values are:  $R_1 = 510 \Omega$ ,  $C_1 = 47 \mu F$ .

In case of figure 1, capacitor,  $C_1$ , has a value of  $10 \mu F$ ,

because a diode is connected between  $V_{Batt}$  and resistance,  $R_1$ .

The integrated Z-diode (14 V) protects the supply voltage,  $V_S$ , therefore, the operation of the IC is possible between 6 V and 16 V, supplied by  $V_{Batt}$ .

However, it is possible to operate the integrated circuit with a 5 V supply, but it should be free of interference voltages. In this case, Pin 7 is connected to Pin 8 as shown in figure 2b, and the  $R_1 C_1$  circuit is omitted.

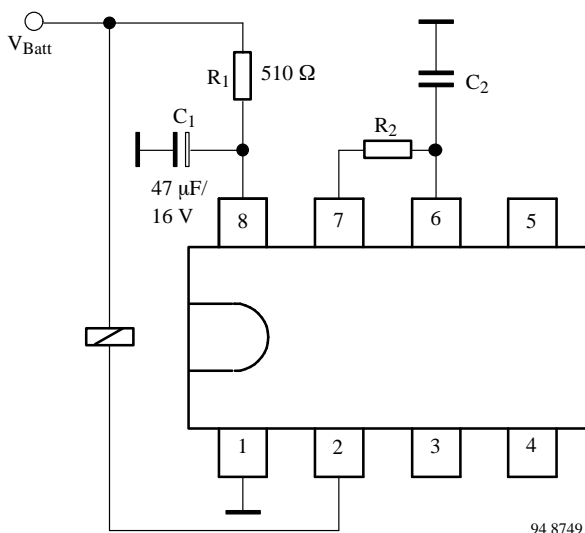

Figure 2a Basic circuit for 12 V voltage supply and oscillator

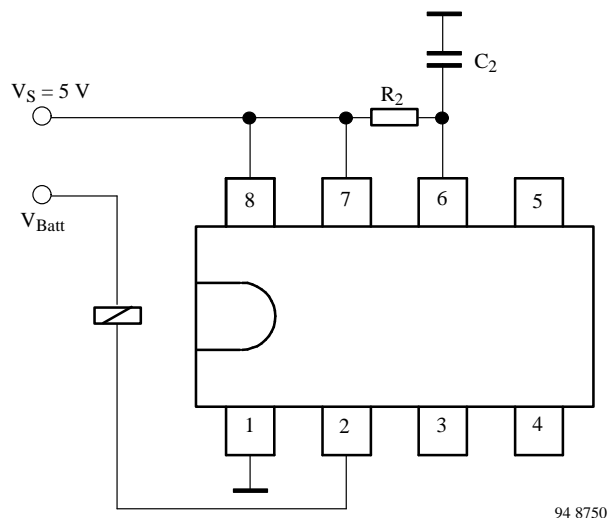

Figure 2b Basic circuit for  $V_S = 5 V$

## Oscillator, Pin 6

Oscillator frequency,  $f$ , is determined mainly by  $R_2C_2$ -circuit. Resistance,  $R_2$ , determines the charge time, whereas the integrated resistance (2 k $\Omega$ ) is responsible for discharge time. For the stability of the oscillator frequency, it is recommended to select  $R_2$  much greater than internal resistance (2 k $\Omega$ ), because the temperature response and the tolerances of the integrated resistance are considerably greater than the external resistance value.

Oscillator frequency,  $f$ , is calculated as follows:

$$f = \frac{1}{t_1 + t_2}$$

where

$$t_1 = \text{charge time} = \alpha_1 \cdot R_2 \cdot C_2$$

$$t_2 = \text{discharge time} = \alpha_2 \cdot 2 \text{ k}\Omega \cdot C_2$$

$\alpha_1$  and  $\alpha_2$  are constants and has

$$\alpha_1 = 0.833 \text{ and } \alpha_2 = 1.551 \text{ when } C_2 = 470 \text{ pF to } 10 \text{ nF}$$

$$\alpha_1 = 0.746 \text{ and } \alpha_2 = 1.284 \text{ when } C_2 = 10 \text{ nF to } 4700 \text{ nF}$$

Debounce time,  $t_3$ , and the delay time,  $t_d$ , depend on the oscillator frequency,  $f$ , as follows:

$$t_3 = 6 \cdot \frac{1}{f}$$

$$t_d = 73728 \cdot \frac{1}{f}$$

Table 1 shows relationships between  $t_3$ ,  $t_d$ ,  $C_2$ ,  $R_2$  and frequencies from 1 Hz to 20 kHz.

## Output, Pin 2

Output Pin 2 is an open collector Darlington circuit with integrated 23-V Z-diode for limitation of the inductive cut-off pulse of the relay coil. The maximum static collector current must not exceed 300 mA and the saturation voltage is typically 1.1 V @ 200 mA.

The output stage can be activated

- directly with the AC input independent of the ignition input and  $S_{th}$  input
- during the delay time which is started by the ignition input with the  $S_{th}$  input

## Interference voltages and load dump

The IC supply is protected by  $R_1$ ,  $C_1$ , and an integrated Z-diode, while the inputs are protected by a series resistor, integrated Z-diode and RF-capacitor (refer to Figure 3).

The relay control output is protected via the integrated 23-V Z-diode in the case of short interference peaks. It is switched to conductive condition for a battery voltage of greater than approx. 40 V in the case of load dump. The

output transistor is dimensioned so that it can withstand the current produced.

## Power-on reset

When the operating voltage is switched on, an internal power-on reset pulse (POR) is generated which sets the logic of the circuits to a defined initial condition. The relay control output is disabled.

## Input stages

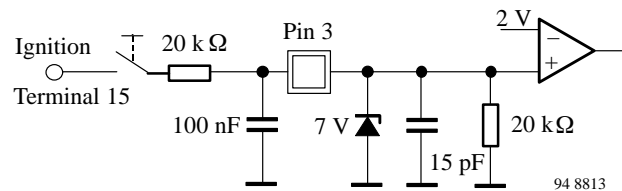

Figure 3a Input circuit for ignition (Pin 3)

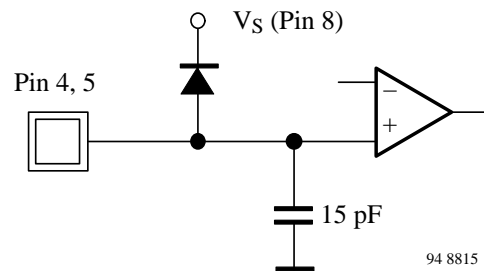

Figure 3b Input circuit Pin 4 and Pin 5

Figure 3a shows the internal input circuit of ignition (Pin 3). It has an integrated pull-down resistor (20 k $\Omega$ ), RF-capacitor (15 pF) and 7-V Z-diode. It reacts to voltages greater than 2 V.

The thermal switch input,  $S_{th}$ , is internally debounced and only needs an external protection resistor. The air conditioning input, AC, and the signal input, ignition, are not debounced and external R/C filters are recommended to prevent the integrated circuit from unintentional activation by transients.

The ignition input is switched to  $V_{Batt}$ , the  $S_{th}$  and AC inputs are switched to GND and need pull up resistors externally (figure 3b).

The detection threshold voltage of all three input stages is typically 2 V.

Ignition input (terminal 15) is not debounced. Debouncing can be achieved by external circuit ( $R_3, C_3$ ) connected to Pin 3 (see figures 1 and 5).

## U 6044 B

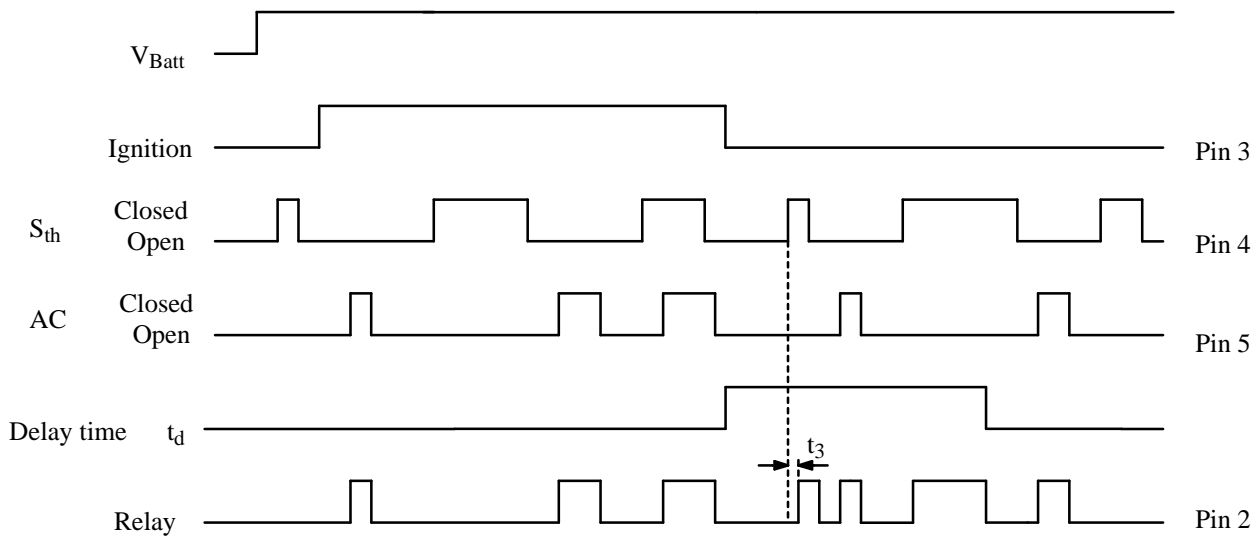

93 7746 e

Figure 4 Timing waveform

### Relay control output behaviour, Pin 2, figure 4

Integrated circuit controls the cooling fan motor in automobile by means of a relay.

Relay control output, Pin 2, is disabled when the battery voltage,  $V_{Batt}$ , is applied. Relay control output follows the conditions of the switch,  $S_{th}$ , during the delay time,  $t_d$ , which starts when the ignition is switched-OFF. This is possible only after the debounce time,  $t_3$ .

### Air condition input, Pin 5

The relay control output, Pin 2 follows the condition of the AC input, independent of operating conditions.

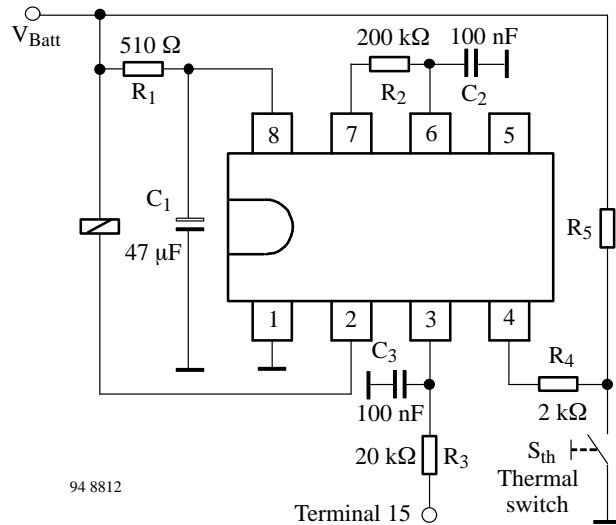

94 8812

Figure 5 Basic circuit

## Absolute Maximum Ratings

Parameters	Symbol	Value	Unit
Operating voltage t = 1 min t = 60 min	$V_{Batt}$	24 18	V
Ambient temperature range	$T_{amb}$	-40 to +125	°C
Storage temperature range	$T_{stg}$	-55 to +125	°C
Junction temperature	$T_j$	150	°C

## Thermal Resistance

Parameters	Symbol	Maximum	Unit
Junction ambient DIP 8 SO 8	$R_{thJA}$ $R_{thJA}$	110 160	K/W K/W

## Electrical Characteristics

$V_{Batt} = 13.5$  V,  $T_{amb} = 25$ °C, reference point ground, figure 2, unless otherwise specified

Parameters	Test Conditions / Pin	Symbol	Min	Typ	Max	Unit
Operating voltage	$R_1 \geq 510 \Omega$ t = 1 min t = 60 min	$V_{Batt}$	6		16 24 18	V
5 V supply	Without $R_1, C_1$ figure 2b Pins 7 and 8	$V_8, V_7$	4.3		6.0	V
Stabilized voltage	Pin 7	$V_7$	5.0	5.2	5.4	V
Undervoltage threshold	Power on reset	$V_S$	2.4		4.2	V
Supply current	Push-buttons open Pin 8	$I_S$			1.0	mA
Internal Z-diode	$I_8 = 10$ mA Pin 8	$V_Z$	13.5	14	16	V
<b>Relay output</b> Pin 2						
Saturation voltage	$I_2 = 200$ mA $I_2 = 300$ mA	$V_2$		1.2	1.5	V
Leakage current	$V_2 = 14$ V	$I_{lkg}$		2	100	µA
Output current		$I_2$			300	mA
<b>Output pulse current</b>						
Load dump pulse		$I_2$			1.5	A
Internal Z-diode	$I_2 = 10$ mA	$V_2$	20	23	24	V
<b>Oscillator input</b> f = 0.001 to 40 kHz, see table 1 Pin 6						
Internal discharge resistance		$R_6$	1.6	2.0	2.4	kΩ
Switching voltage	Lower Upper	$V_{6L}$ $V_{6H}$	0.9 2.8	1.1 3.1	1.4 3.5	V
Input current	$V_6 = 0$ V	$-I_6$			1	µA
<b>Switching times</b>						
Debounce time		$t_3$	5		7	cycles
Delay time	cooling off period	$t_d$	72704		74752	cycles
<b>Inputs</b> Pin 3, 4, 5						
Switching threshold		$V_{3,4,5}$	1.6	2.0	2.4	V
<b>Ignition input</b> Pin 3						
Pull-down resistance	Switched to $V_{Batt}$ (15)	$R_3$	13	20	50	kΩ
Protective diode	$I_3 = 10$ mA	$V_3$	6.5	7.1	8.0	V
<b>Thermal switch</b> Pin 4						
Input current	$V_4 = 0$ V	$-I_4$			2	µA
<b>Air condition input</b> Pin 5						
Input current	$V_5 = 0$ V	$-I_5$			2	µA

Table 1 Oscillator frequency, debounce and delay time dimensioning

Fre- quency f	De- bounce time t <sub>3</sub>	Delay time t <sub>d</sub>		C <sub>2</sub> nF	R <sub>2</sub> kΩ
		min	s		
1	6000	1229		4700	280
2	3000	614		1000	650
3	2000	410		1000	440
4	1500	307		1000	330
5	1200	246		1000	260
6	1000	205		1000	220
7	857	176		1000	190
8	750	154		1000	160
9	667	137		1000	140
10	600	123		1000	130
20	300	61		100	650
30	200	41		100	440
40	150	31		100	330
50	120	25		100	260
60	100	20		100	220
70	86	18		100	190
80	75	15		100	160
90	67	14		100	140
100	60	12		100	130
200	30		369	10	600
300	20		246	10	400
400	15		184	10	300
500	12		147	10	240

Fre- quency f	De- bounce time t <sub>3</sub>	Delay time t <sub>d</sub>		C <sub>2</sub> nF	R <sub>2</sub> kΩ
		min	s		
600	10		123	10	200
700	9		105	10	170
800	8		92	10	150
900	7		82	10	130
1000	6		74	10	120
2000	3.00		37	1	600
3000	2.00		25	1	400
4000	1.50		18	1	300
5000	1.20		15	1	240
6000	1.00		12	1	200
7000	.86		11	1	170
8000	.75		9	1	150
9000	.67		8	1	130
10000	.60		7	1	120
11000	.55		6.7	1	110
12000	.50		6.1	1	99
13000	.46		5.7	1	91
14000	.43		5.3	1	85
15000	.40		4.9	1	79
16000	.38		4.6	1	74
17000	.35		4.3	1	70
18000	.33		4.1	1	66
19000	.32		3.9	1	62
20000	.30		3.7	1	59

## Dimensions in mm

Package: DIP 8

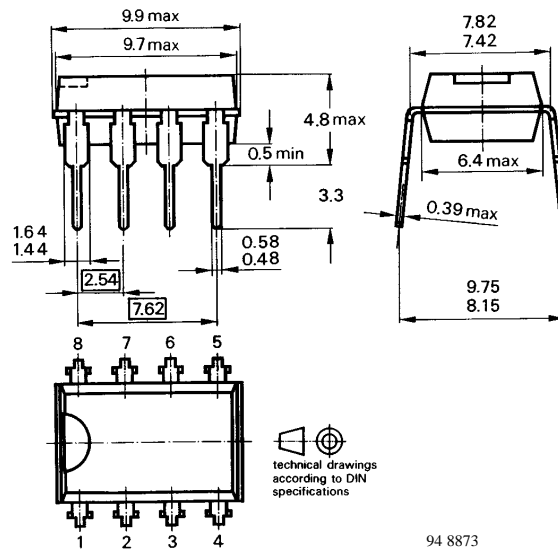

Package: SO 8

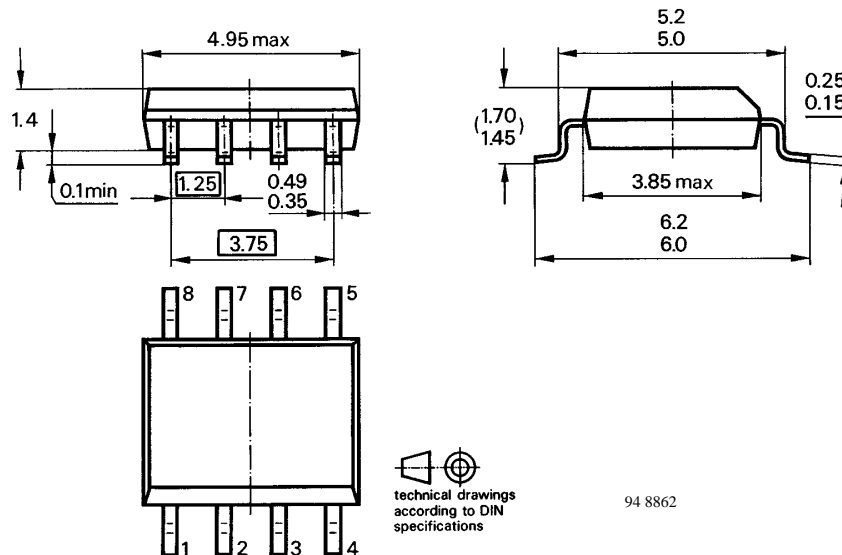

**We reserve the right to make changes to improve technical design without further notice.**

Parameters can vary in different applications. All operating parameters must be validated for each customer application by the customer. Should the buyer use TEMIC products for any unintended or unauthorized application, the buyer shall indemnify TEMIC against all claims, costs, damages, and expenses, arising out of, directly or indirectly, any claim of personal damage, injury or death associated with such unintended or unauthorized use.

TEMIC TELEFUNKEN microelectronic GmbH, P.O.B. 3535, D-74025 Heilbronn, Germany  
 Telephone: 49 (0)7131 67 2831, Fax Number: 49 (0)7131 67 2423